



# What do people really want from their NHS service now?

**Dan Wellings, Ipsos MORI Social Research Institute**

**19<sup>th</sup> November**



*"We now expect more of government than we do of God"*

*52% of the public agree*

Nowhere is this more  
true than in the NHS –  
let's examine why

*Are voters and taxpayers getting the healthcare system they want?*

# Health not a pressing concern but we have other issues to worry about...

*What do you see as the most/other important issues facing Britain today?*

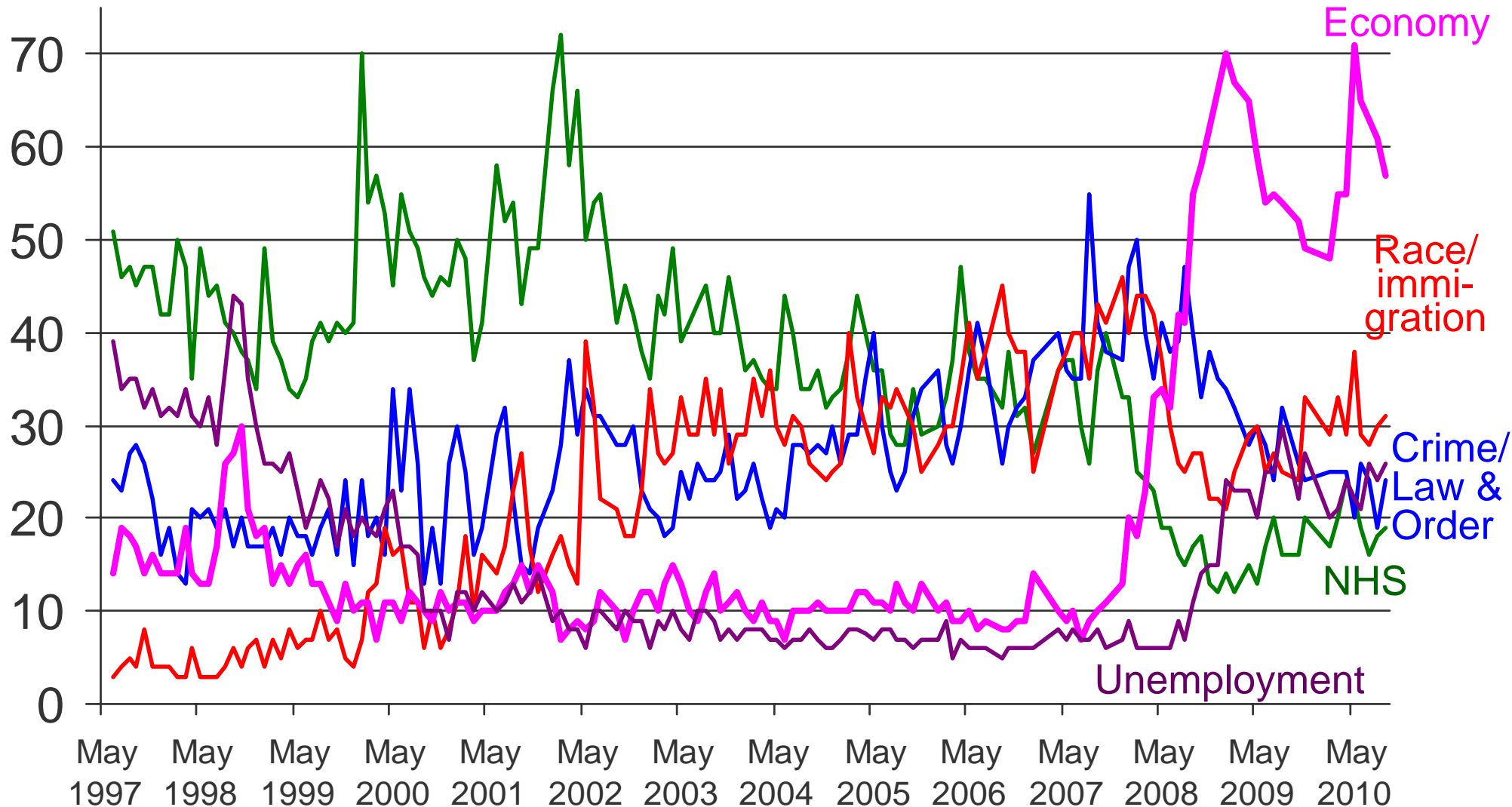

# Rising satisfaction in the last decade

Q Overall, how satisfied or dissatisfied are you with the running of the National Health Service nowadays?

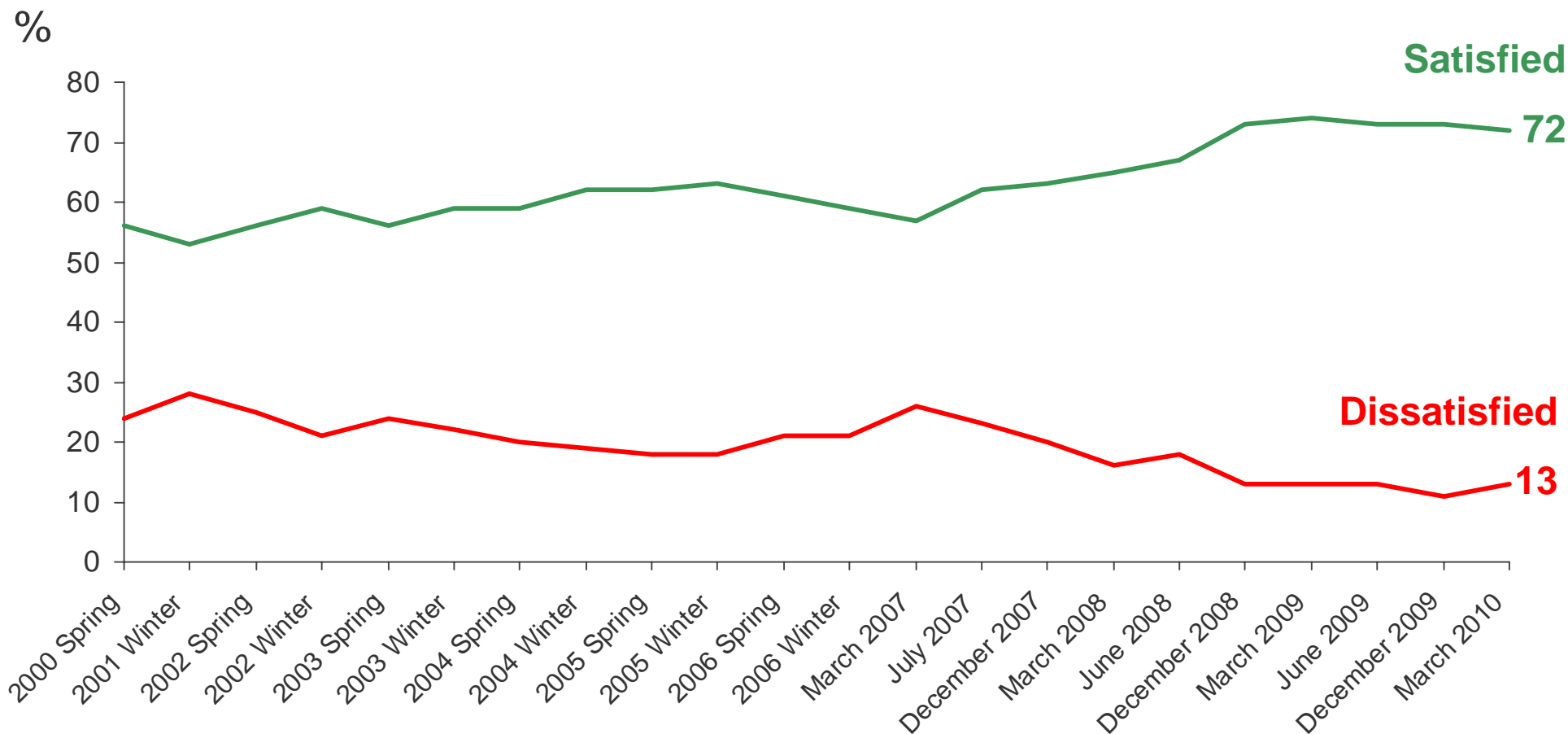

Base: English adults aged 16+ (c.1,000 per wave)

# Increased satisfaction with the NHS across all regions

Q Overall, how satisfied or dissatisfied are you with the running of the National Health Service nowadays?

% Satisfied ■ 2008-2010 ■ 2002-2007

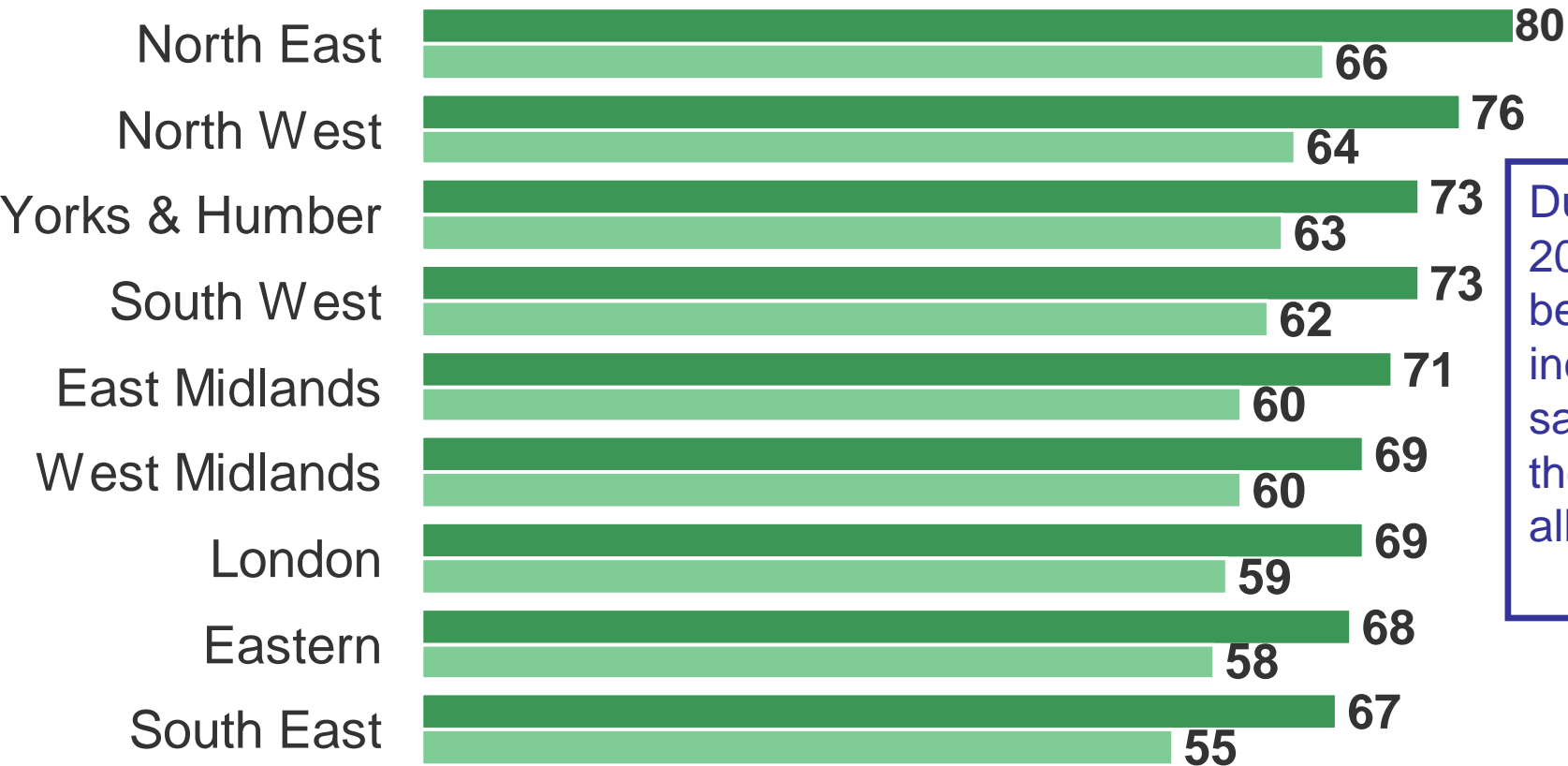

During 2008 to 2010 there have been significant increases in satisfaction with the NHS across all regions.

Base: Ipsos MORI aggregate analysis English adults aged 16+, March 2008 – March 2010 (7,110), Winter 2002 – December 2007 (12,283)

# Patient satisfaction with the NHS – users v non-users

Q Overall, how satisfied or dissatisfied are you with the running of the National Health Service nowadays?

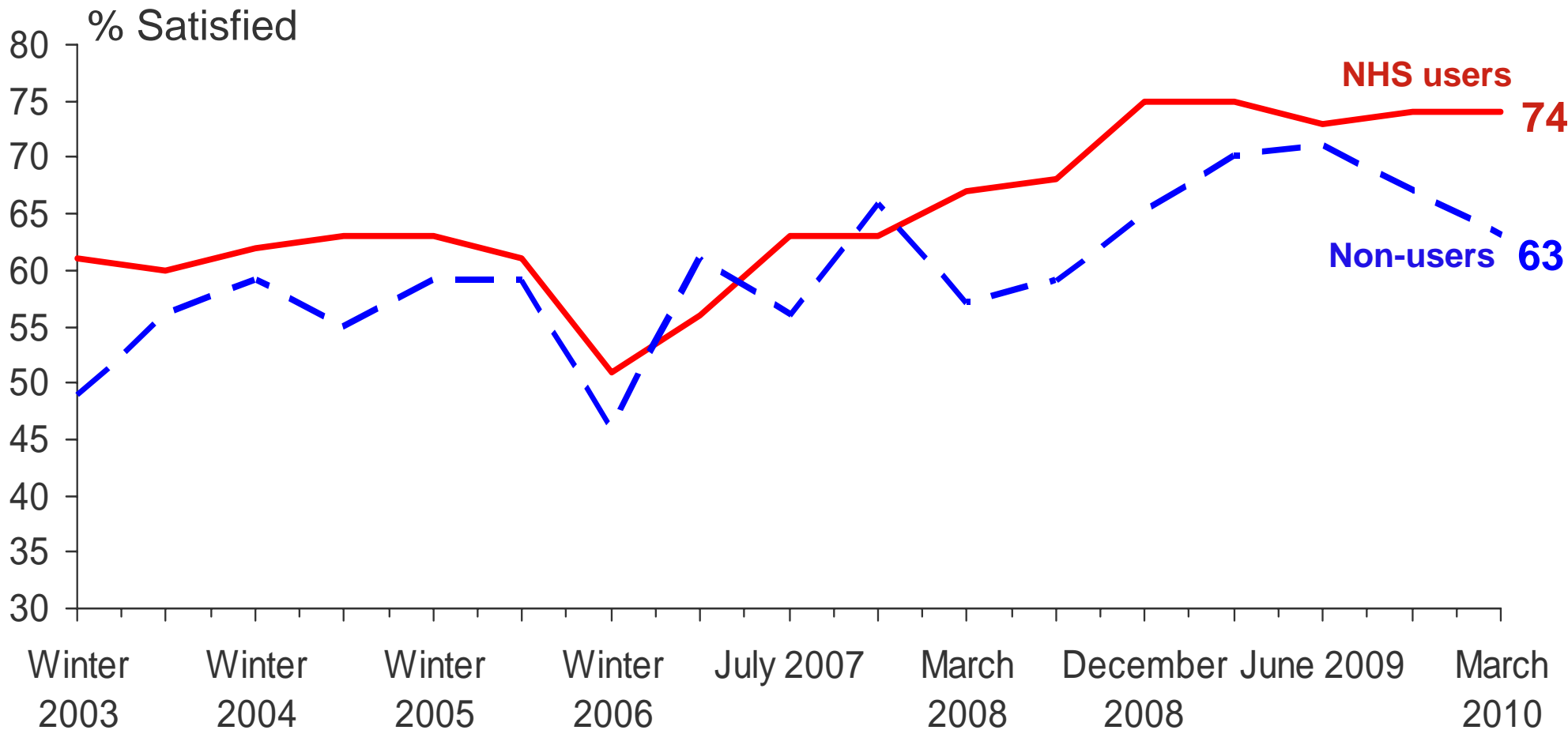

Base: English adults aged 16+. NHS users (884), Non-users (122)  
 NHS users are those who have been personally been an inpatient, outpatient, A&E patient or used a walk-in clinic or visited an NHS GP within the last year

# NHS perception gap

Q To what extent, if at all, do you agree or disagree with the following statements?

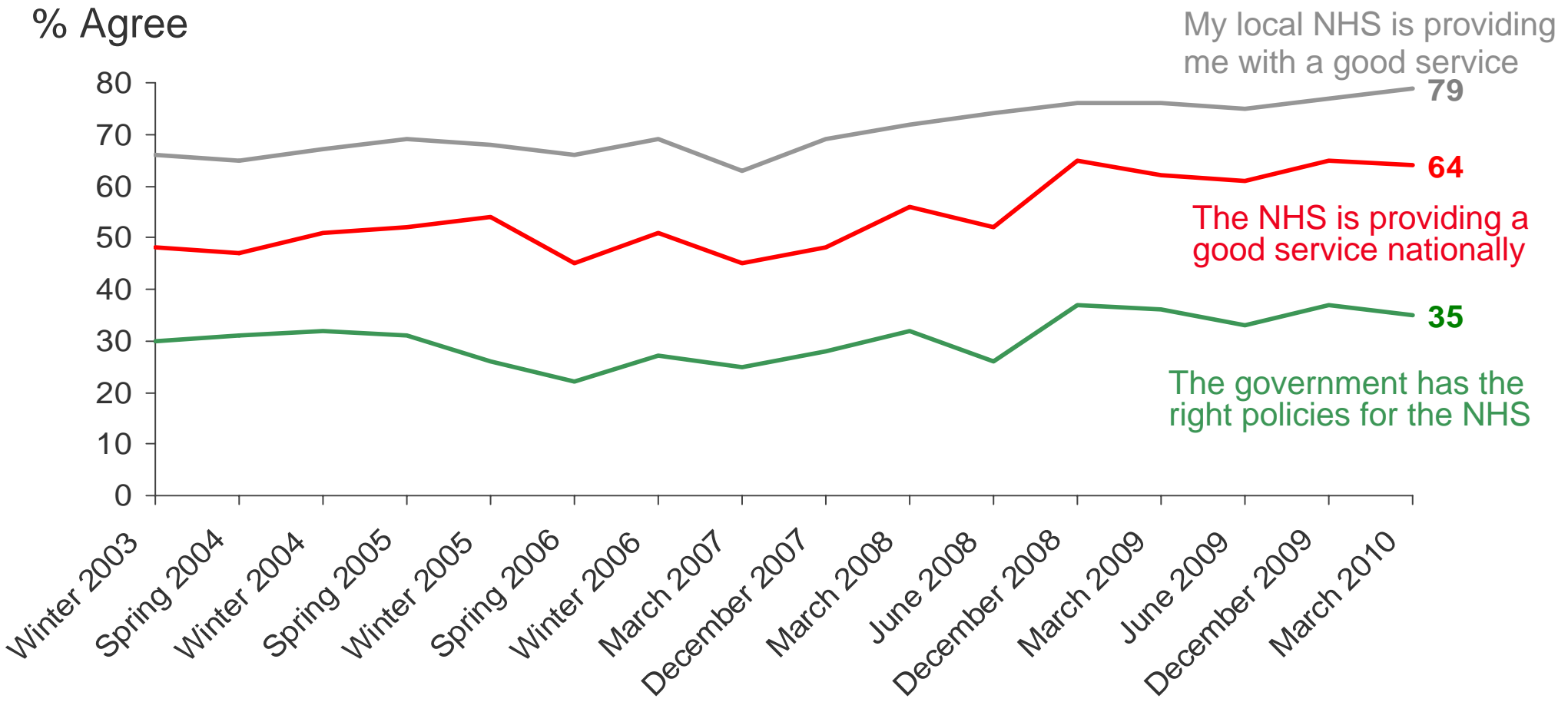

Base: English adults aged 16+ (c.1,000 per wave)

Ipsos MORI

Source: Ipsos MORI/DH Perceptions of the NHS Tracker



So excellent progress  
but in a time of  
unprecedented  
investment we still  
thought funding was  
the biggest issue

# The public still believe there is waste and inefficiency in the NHS

Q Please tell me whether on the whole you agree or disagree with each of the following statements:

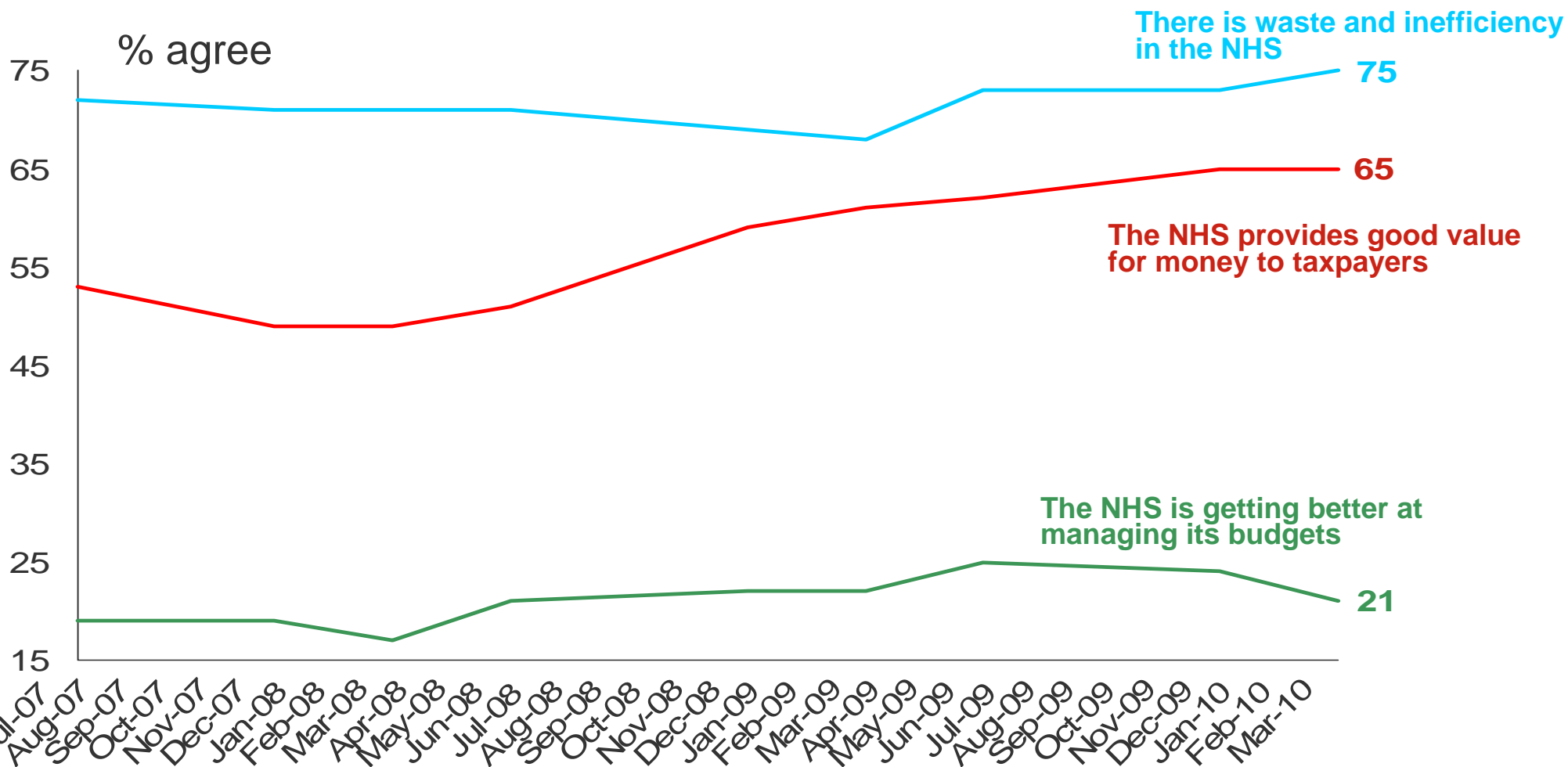

Base: 1,006 English adults aged 16+, March 2010

Ipsos MORI

Source: Ipsos MORI/DH Perceptions of the NHS Tracker



# Biggest Problems facing the NHS – top 6

What do you see as the biggest problems facing the NHS? What else?

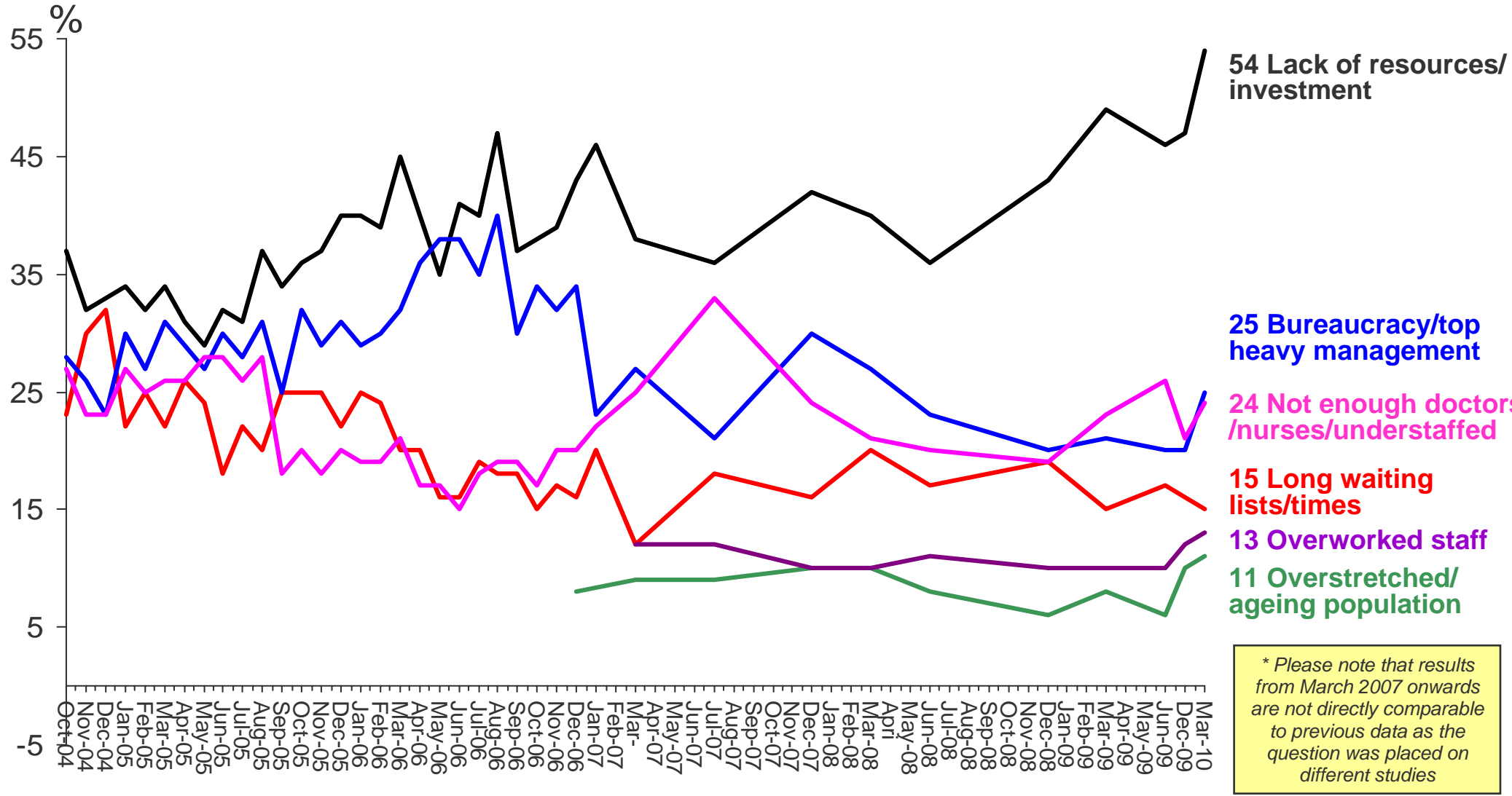

# NHS budget should be 'ring-fenced'

Q Which TWO or THREE, if any, of the following main areas of public spending do you think **should be protected from any cuts**?

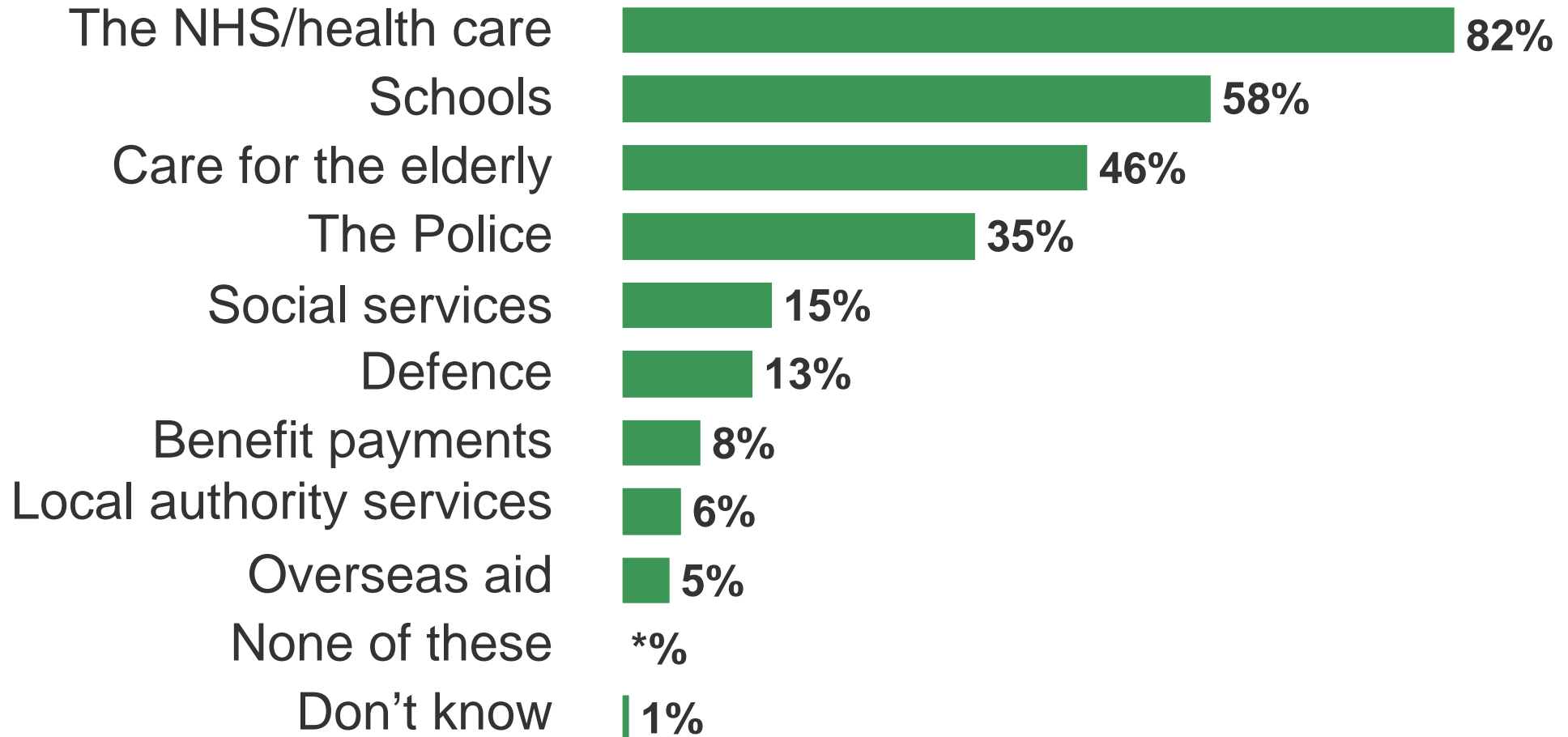

Base: British adults aged 18+ 19-21 June 2009, all who think some services should be protected (773)

So Coalition commitment  
*“We will guarantee that health  
spending increases in real terms”*

So how much funding do we think it should have?

# Expectations unrealistically high. People want ... unlimited spending...

*There should always be limits on what is spent on the NHS...*

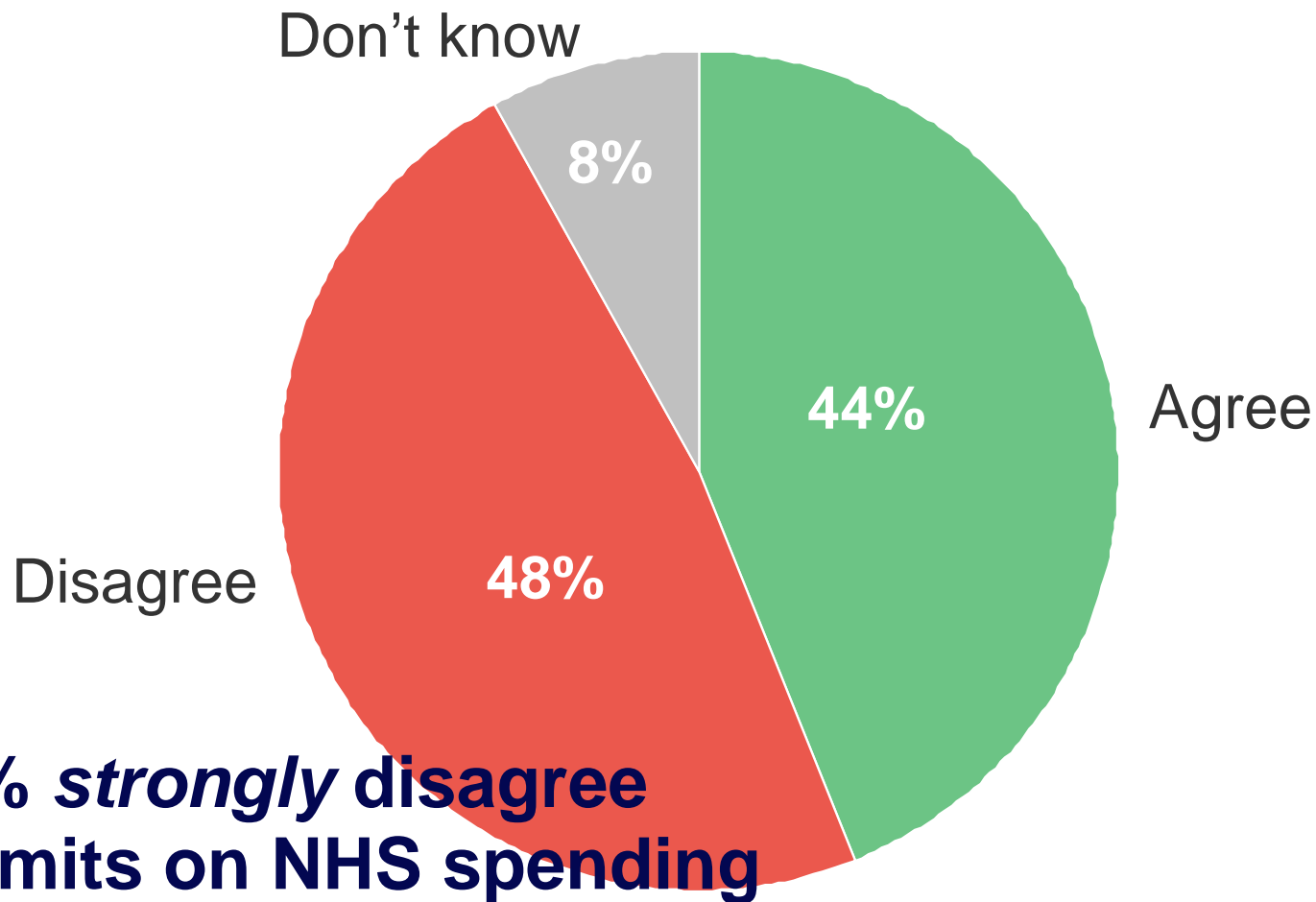

Base: British public, 18+ (1,001) 12-17 January 2006

Ipsos MORI

# ... and little concern about value for money

The NHS should provide the most effective drugs and treatments provided they represent good value for money

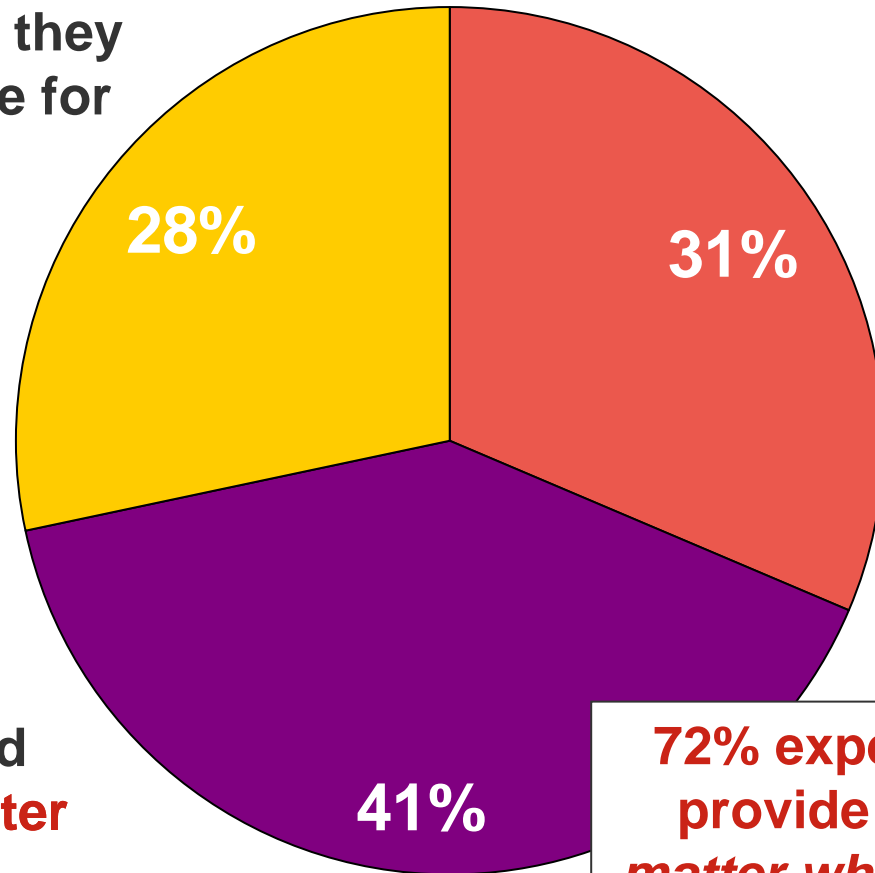

The NHS should provide all drugs and treatments **no matter what they cost**

The NHS should provide the most effective drugs and treatments **no matter what they cost**

**72% expect NHS to provide drugs no matter what they cost**

# We are not particularly keen on paying more for it

*How should NHS budget shortfalls be addressed?*

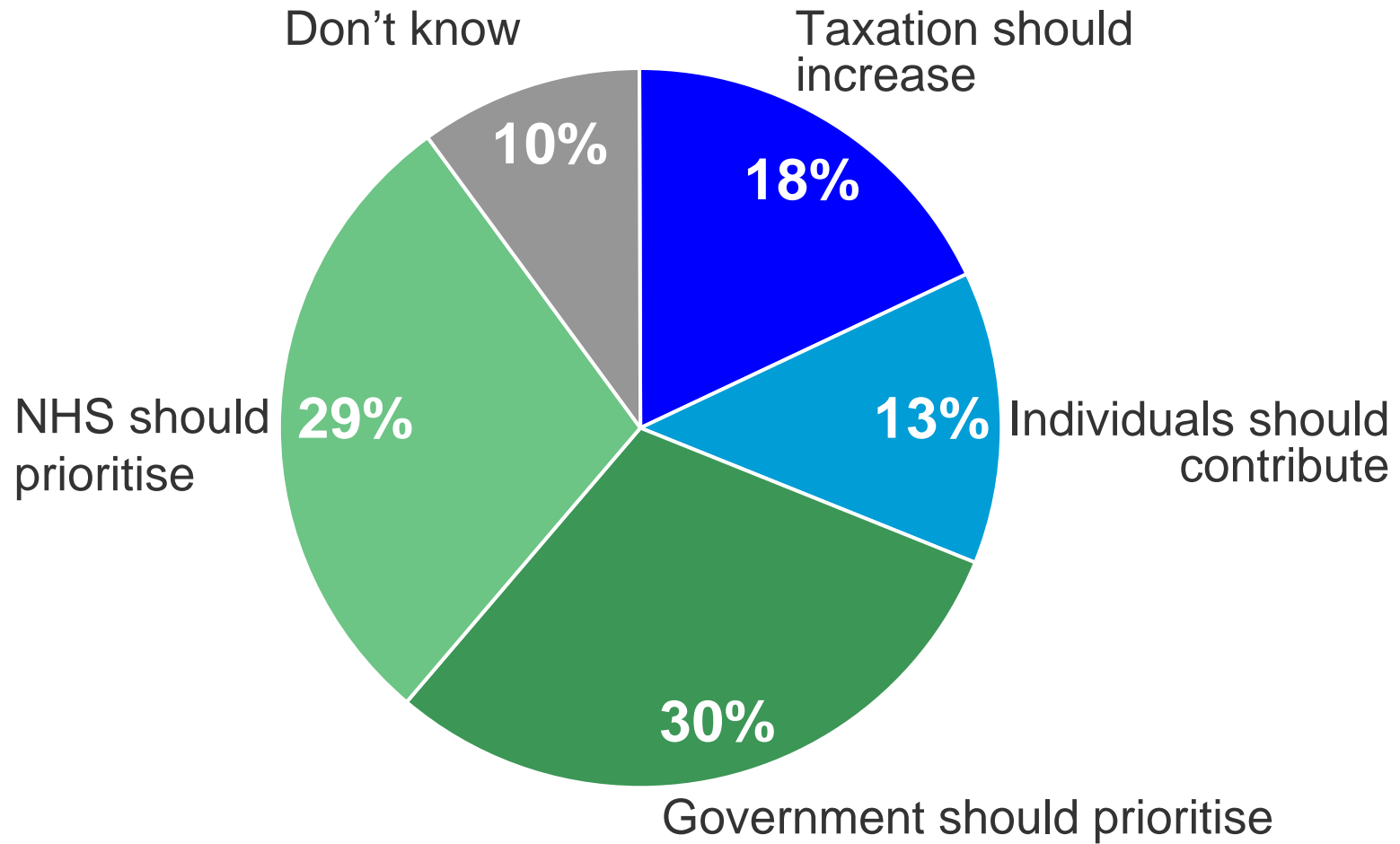

Base: 988 English adults (18+), November 2008

Source: Ipsos MORI/Social Market Foundation

# Sheer scale of NHS makes it difficult to understand scarcity

- We find it hard/scary to acknowledge that the NHS has limits
- Problem for public is understanding who makes these decisions



# However, growing realisation that cuts are necessary

*There is a real need to cut spending on public services in order to pay off the very high national debt we now have*

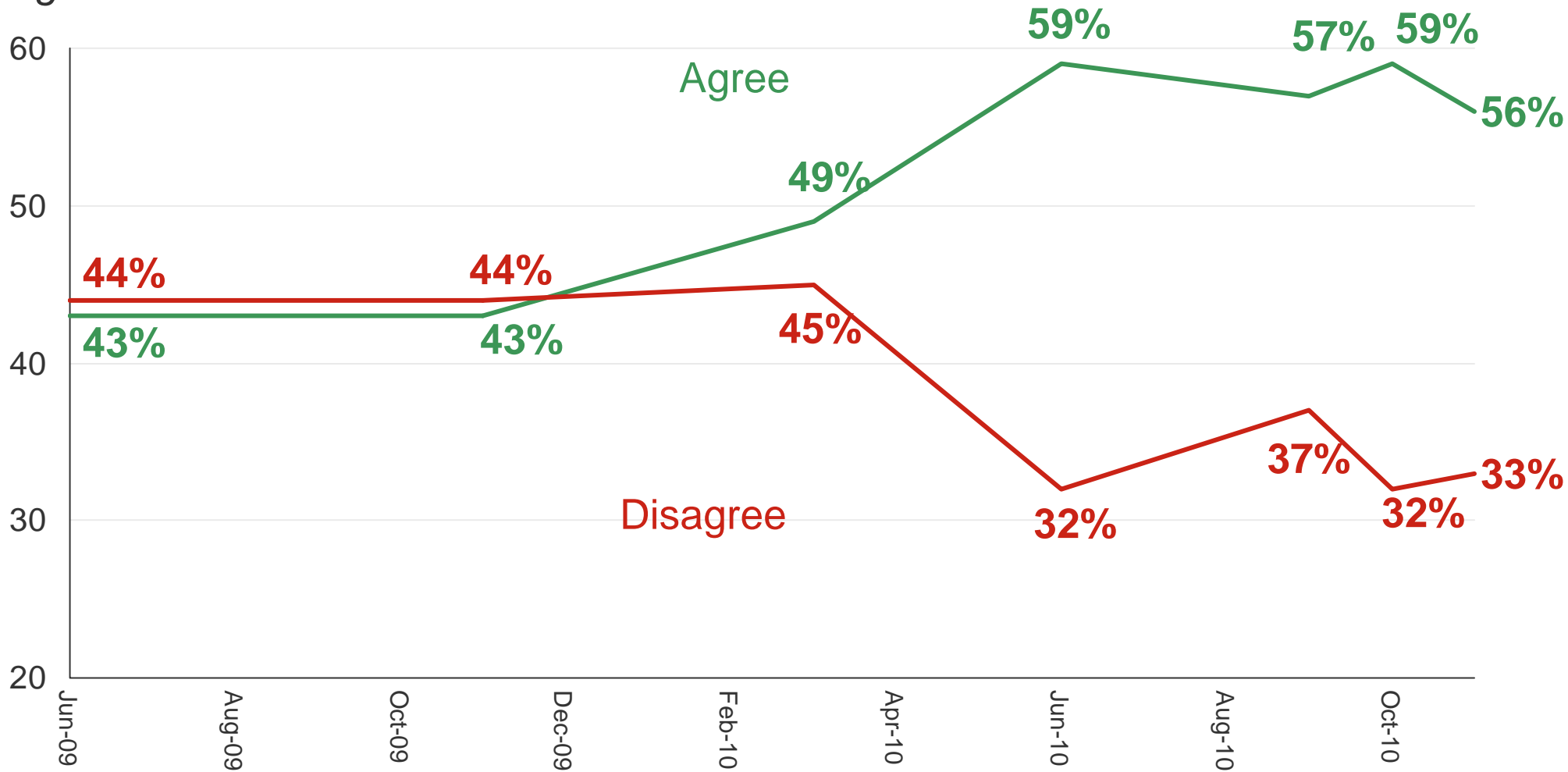

# Are we prepared for cuts in NHS though?



Do we want National or Local?

*OR*

*We want national standards with local control*

# Local versus National

Please read each pair of statements and decide which comes closest to your own opinion

- 1 - agree much more with A
- 2
- 3
- 4
- 5 - agree much more with B

**A. Standards of public services should be the same everywhere in Britain**

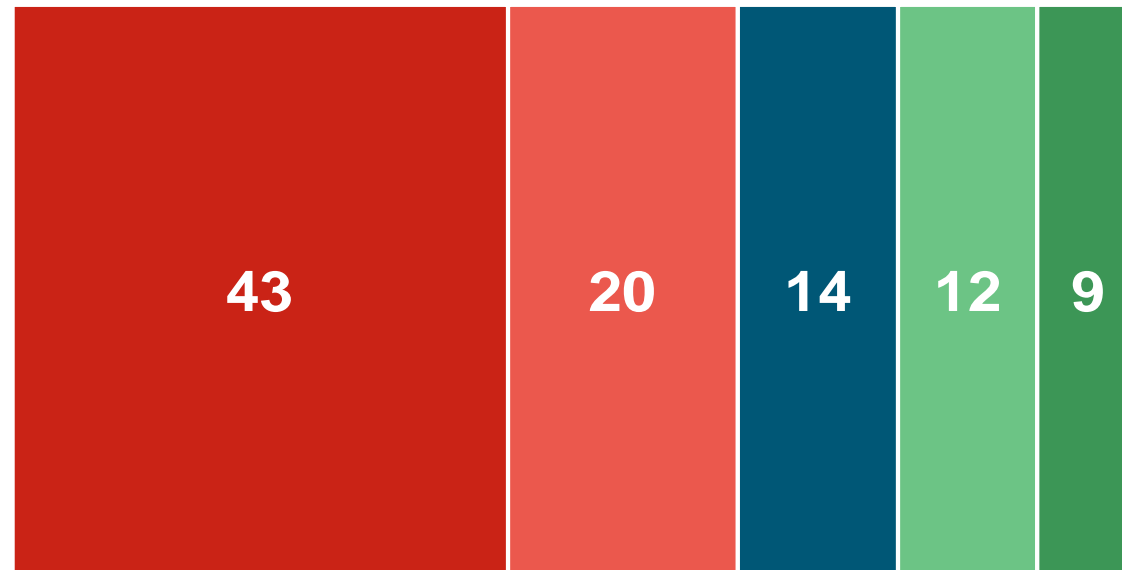

**B. The people who live in different parts of Britain should be able to decide for themselves what standard of public services should be provided in their area**

Base: 2,019 British adults, 9 May-5 June 2008

Source: Ipsos MORI Real Trends

# Views cut across party lines

*Please read each pair of statements and decide which comes closest to your own opinion*

**A. Standards of public services should be the same everywhere in Britain**

■ 1 - agree much more with A  
■ 2  
■ 3  
■ 4  
■ 5 - agree much more with B

**B. The people who live in different parts of Britain should be able to decide for themselves what standard of public services should be provided in their area**

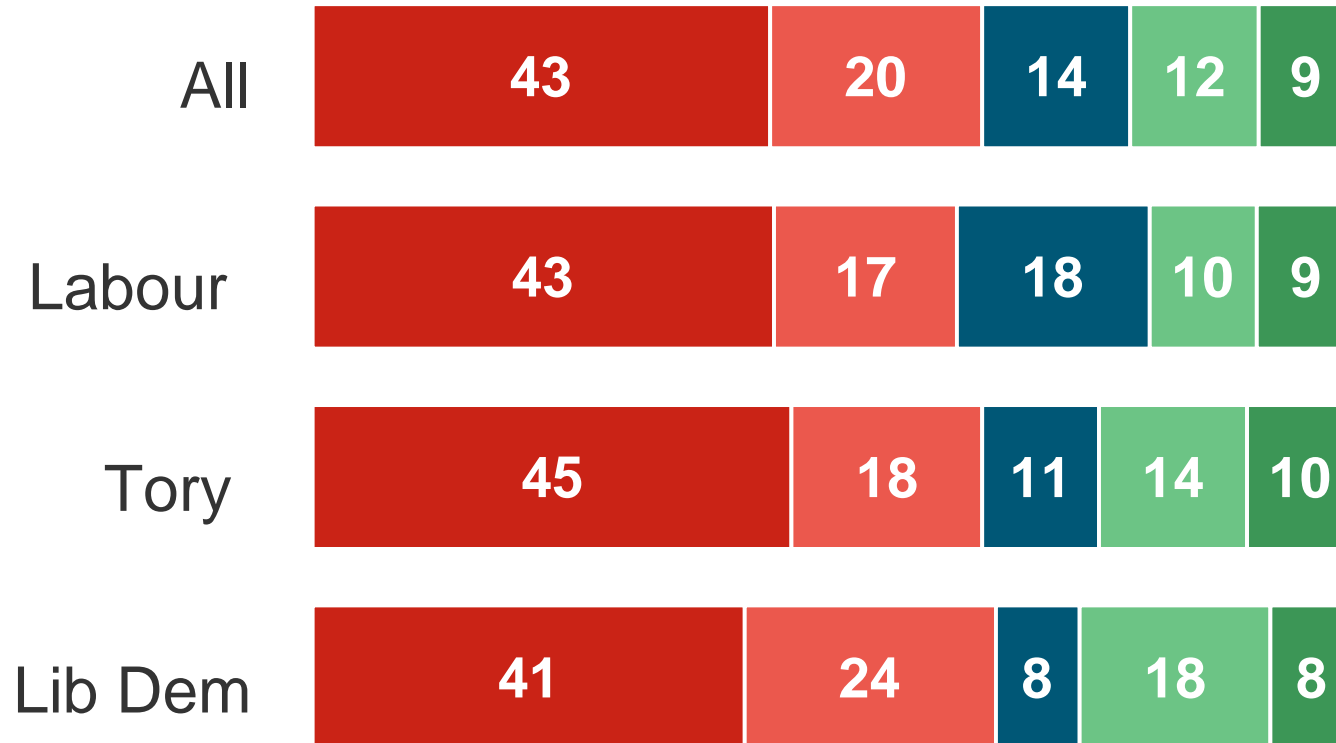

Base: 2,019 British adults, fieldwork dates 9th May – 17th June 2008

# Particularly true of the health service

Q Please can you tell me which of these statements comes closest to your own opinion:

■ ...should be the same everywhere in Britain

■ People should be able to decide for themselves how ... is provided in their area

The health service

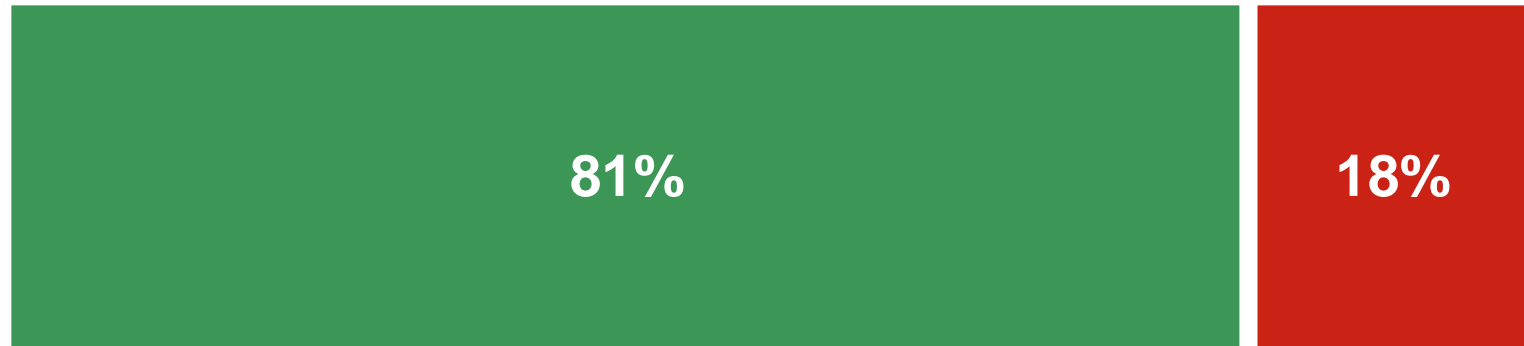

Recycling



Base: 1,002 adults in Great Britain aged 16+. Fieldwork dates: 13-19 May 2010

Ipsos MORI

Source: Ipsos MORI



# This is a challenge for the localism agenda

*And thinking of the treatments that are available on the NHS, which of these statements most closely matches your opinion?*

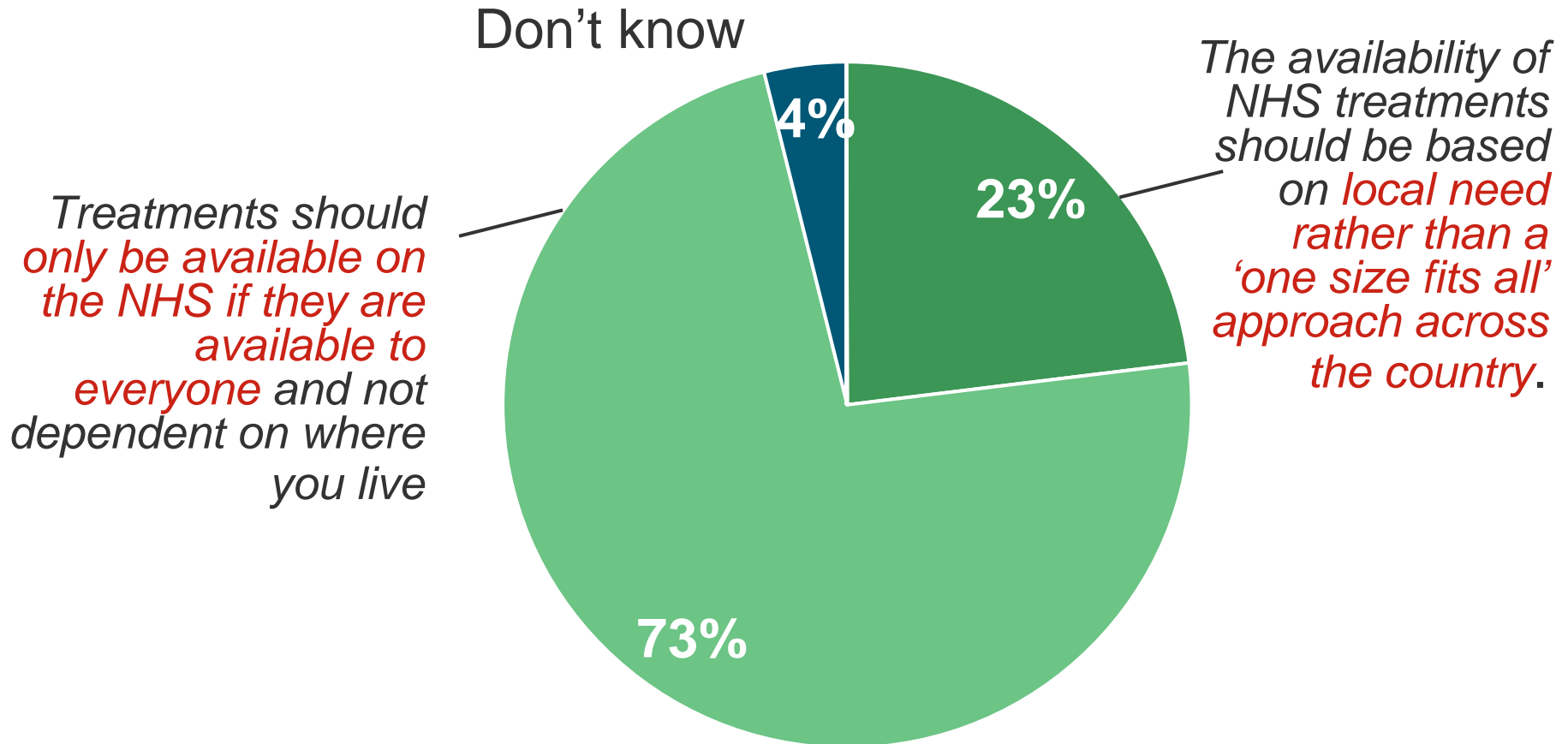

Base: 988 English adults (18+), November 2008

Source: Ipsos MORI/Social Market Foundation

Partly driven by a national obsession with the “postcode lottery” – try entering the term into newspaper search engines...

...a lot of news coverage of “postcode lotteries”



“Over 100 items”

Guardian Unlimited

“637 items”



“A lot!”

***But this is NOT just a media obsession. It is driven by real concerns about fairness. With greater local control people will need more reassurance about minimum standards and support for the less able***

So people want it to be  
fair but what does  
fairness mean?

# Fairness means different things to different people

## Partnership

“Partnership seems to be the best of the 3 options. This seems the **fairest option**. Both the other options involve people who have already contributed all their working lives in paying out yet more money regardless of whether they need care or not.”

## Insurance

“The Insurance option would be easier to collect, more affordable to more people during their earning years, produce more income for the scheme and be **fairer to all**.”

## Comprehensive

“The Partnership model appeals on a selfish level but the Comprehensive model is **much fairer**, particularly with the payment deferral options.”

Do we want choice?  
Answer: sometimes

# Choice versus Uniform Standards

Choice

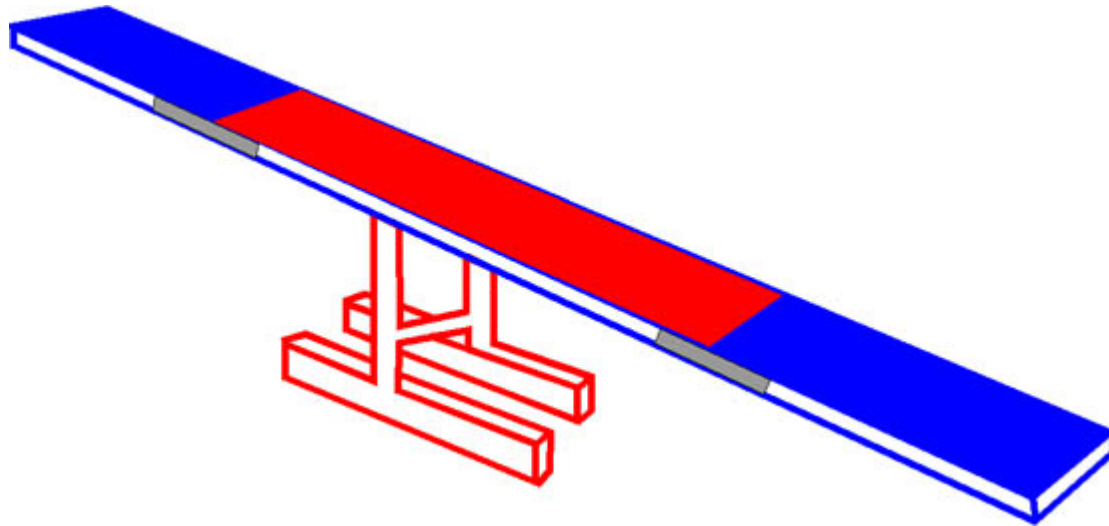

Uniform  
quality

# Choice?

Q. Were you offered a choice of hospital for your first hospital appointment?

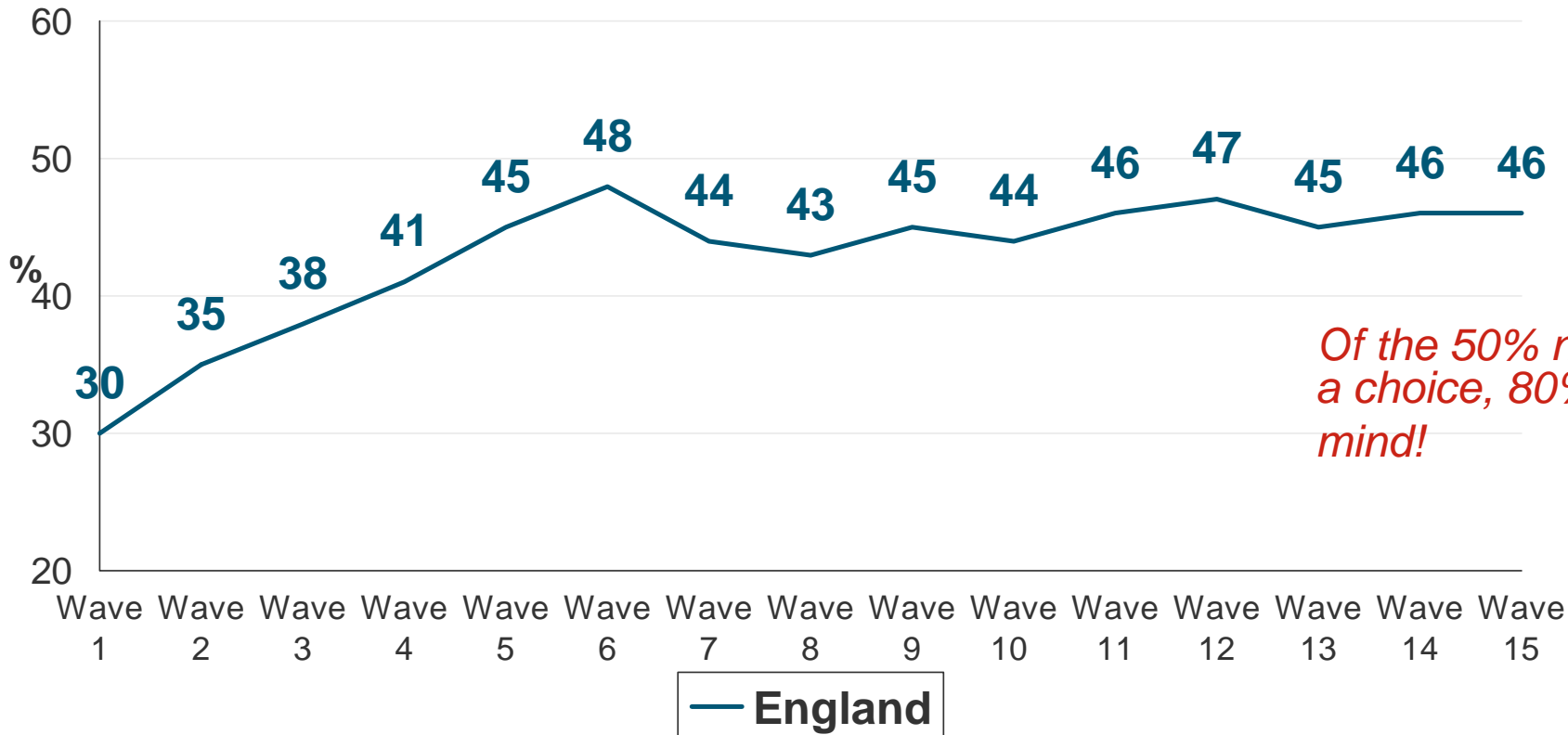

*Of the 50% not offered a choice, 80% did not mind!*

Choice relies on  
information – internet  
is great but...

# Internet usage trends

Which of the following applies to you?

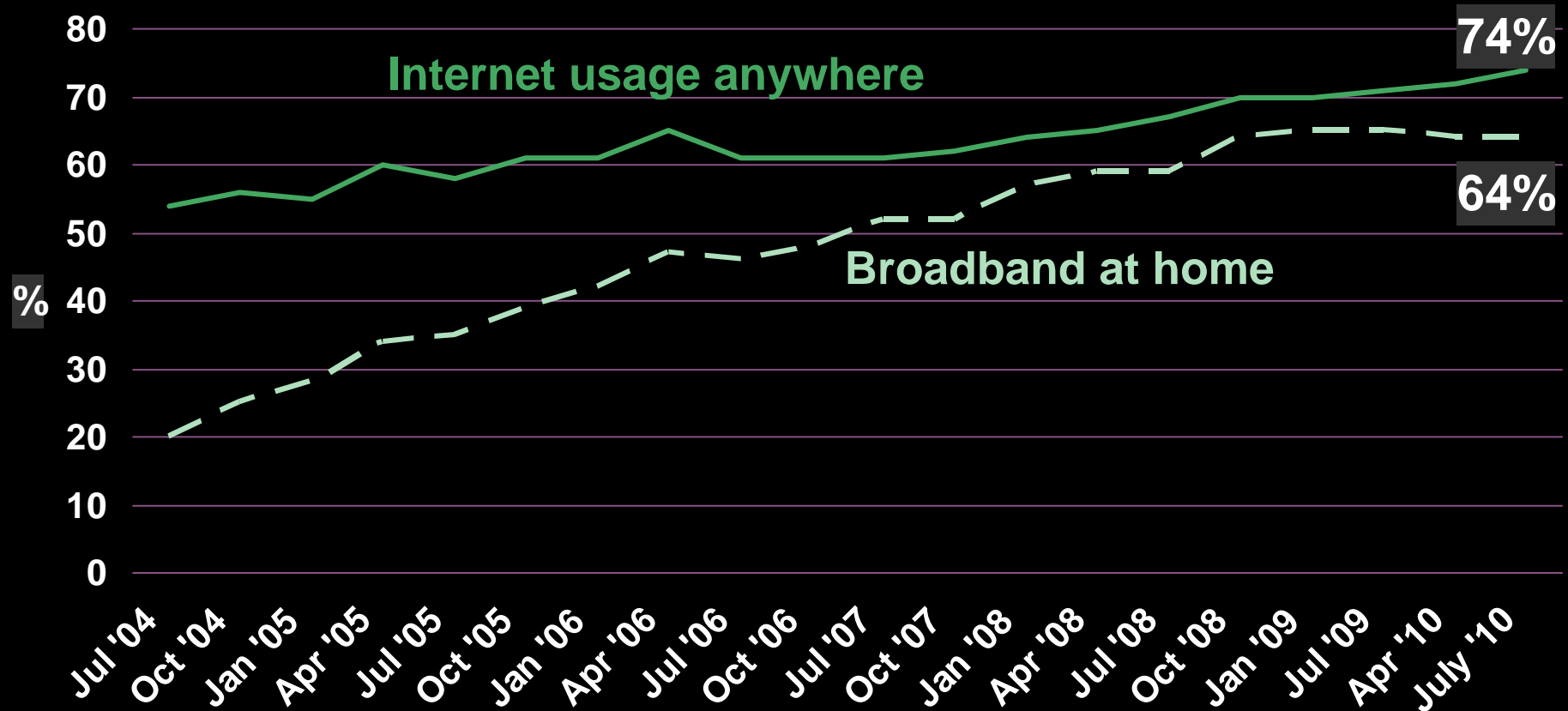

Base: circa 2,000 interviews per wave until January 2010, circa 1,000 GB adults aged 15+ per wave thereafter

Source: Ipsos MORI

# Who is and isn't accessing the internet

**% with internet access at home or at work, 2010 vs 4<sup>th</sup> Quarter 2006**

**%    All    15-24    25-34    35-44    45-54    55-64    65+**

**All**

**AB**

**C1**

**C2**

**DE**

Base: 3,160 GB adults aged 15+: Jan/Apr/Jul 2010 (compared to 10,000 GB adults 15+, Oct-Dec 2006)

# Who is and isn't accessing the internet

**% with internet access at home or at work, 2010 vs 4<sup>th</sup> Quarter 2006**

%	All	15-24	25-34	35-44	45-54	55-64	65+
All	74 <sub>+12</sub>	87 <sub>+13</sub>	87 <sub>+15</sub>	88 <sub>+10</sub>	84 <sub>+12</sub>	67 <sub>+8</sub>	39 <sub>+15</sub>
AB	90 <sub>+11</sub>	99 <sub>+10</sub>	99 <sub>+11</sub>	97 <sub>+4</sub>	97 <sub>+6</sub>	89 <sub>+9</sub>	66 <sub>+24</sub>
C1	82 <sub>+9</sub>	94 <sub>+9</sub>	90 <sub>+11</sub>	87 <sub>+11</sub>	91 <sub>+10</sub>	77 <sub>+7</sub>	41 <sub>+14</sub>
C2	69 <sub>+11</sub>	89 <sub>+15</sub>	75 <sub>+10</sub>	84 <sub>+10</sub>	80 <sub>+10</sub>	58 <sub>+14</sub>	32 <sub>+14</sub>
DE	51 <sub>+14</sub>	70 <sub>+15</sub>	73 <sub>+28</sub>	86 <sub>+14</sub>	53 <sub>+15</sub>	34 <sub>+5</sub>	16 <sub>+8</sub>

Base: 3,160 GB adults aged 15+: Jan/Apr/Jul 2010 (compared to 10,000 GB adults 15+, Oct-Dec 2006)

Do we want to be involved? (Big Society)

# Some scepticism in absence of detail....

To what extent do you agree or disagree with the following statements?

Strongly agree Tend to agree Neither Tend to disagree Strongly disagree  
Don't know

**Big society is a good idea in principle but won't work in practice**

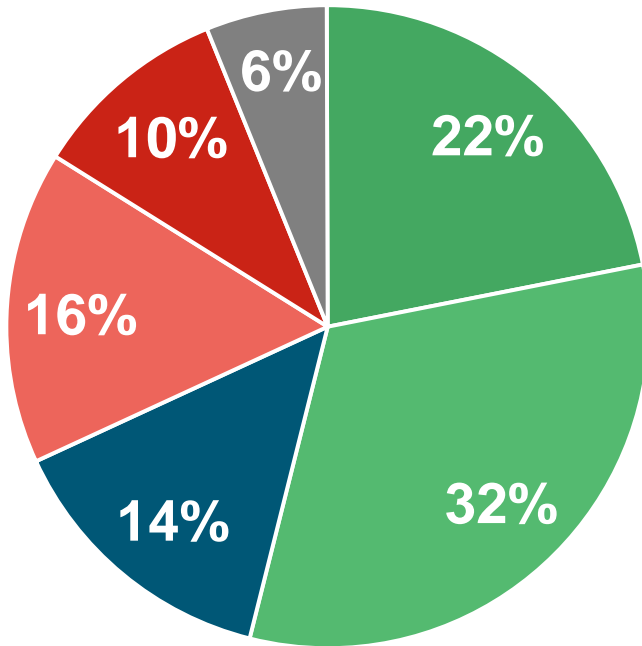

**Big Society is just an excuse for the government to save money by cutting back on public services**

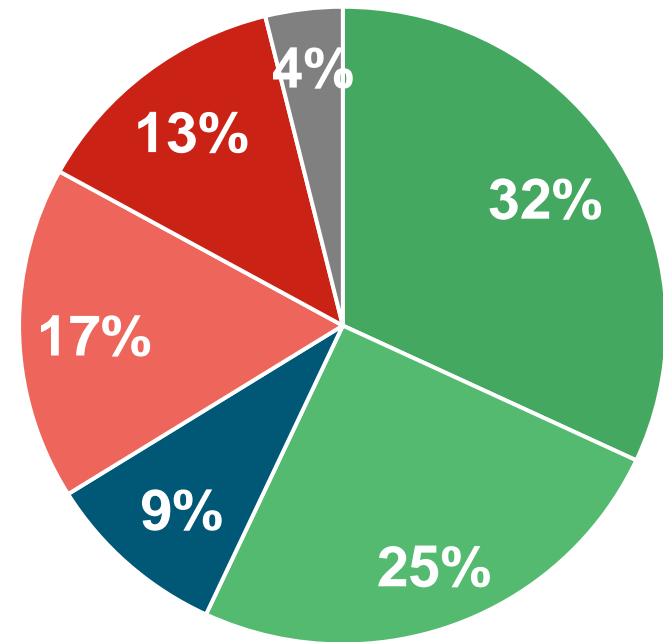

Base: 1,009 British adults, 23<sup>rd</sup> – 25<sup>th</sup> July 2010

# The public say they want to be consulted

*And thinking of how decisions about treatments and services should be made, which of these statements most closely matches your opinion?*

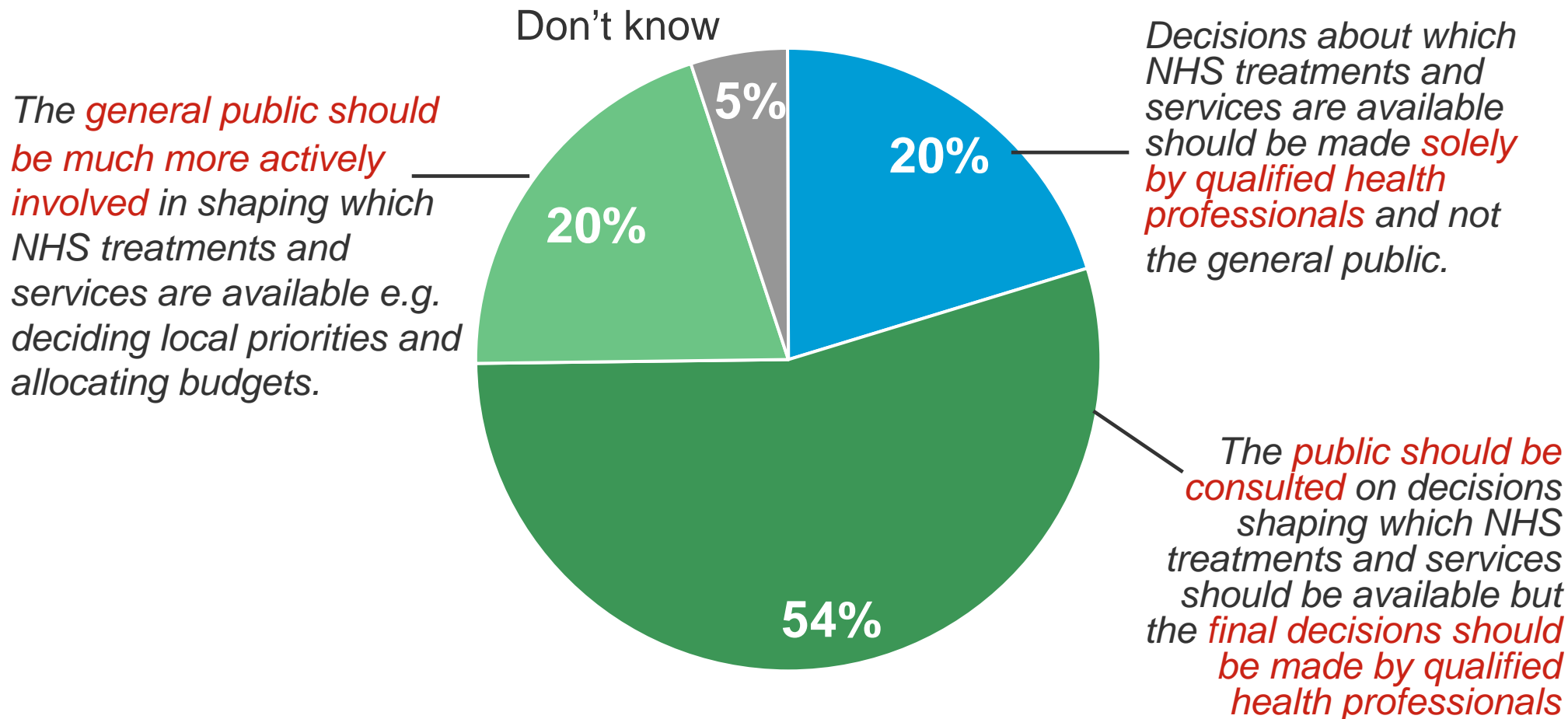

Base: 988 English adults (18+), November 2008

Source: Ipsos MORI/Social Market Foundation

# Big support for getting involved – though in practice...

In principle, would you support or oppose *extending Community Partnerships* to other parts of the Borough?

And would you *personally be interested* in getting involved?

## Support

Don't know/no opinion

12%

No, oppose

6%

Yes, support

82%

Base: All residents (1,021)

Ipsos MORI

## Involvement

Don't know

2%

Depends

18%

Yes

26%

Actual Proportion - 2%

54%

No

Base: All resps who support the idea (835)

So in light of all this what were the initial reactions to the White Paper?

# Pre election – what did people want?

*Please tell me how strongly you support or oppose each of these possible future changes for the National Health Service?*

■ % Strongly support   ■ % Tend to support   ■ % Tend to oppose   ■ % Strongly oppose

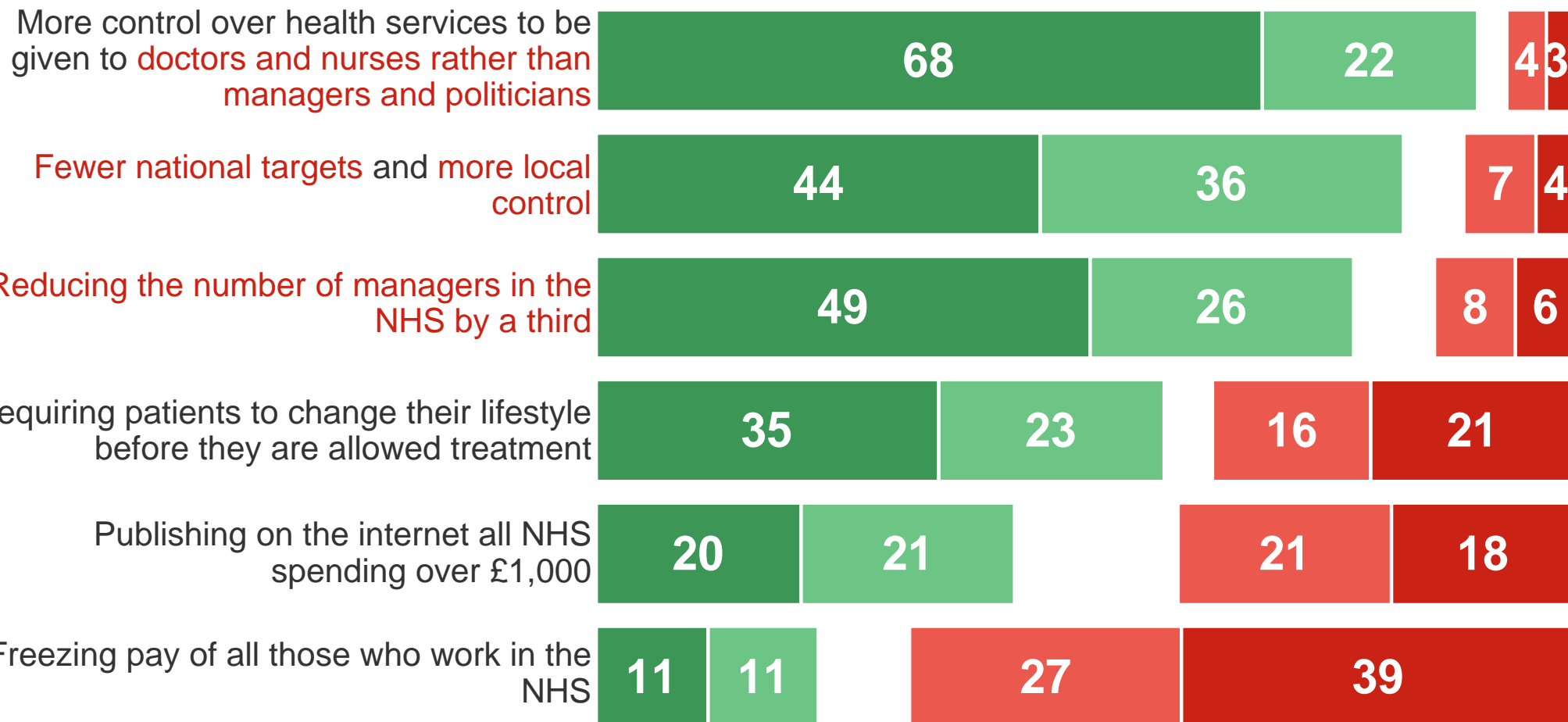

# 1/5 have latched on to GP commissioning but lots of people expecting cuts

The Government has recently announced changes to the way that the NHS will be run. What, if anything have you heard about?

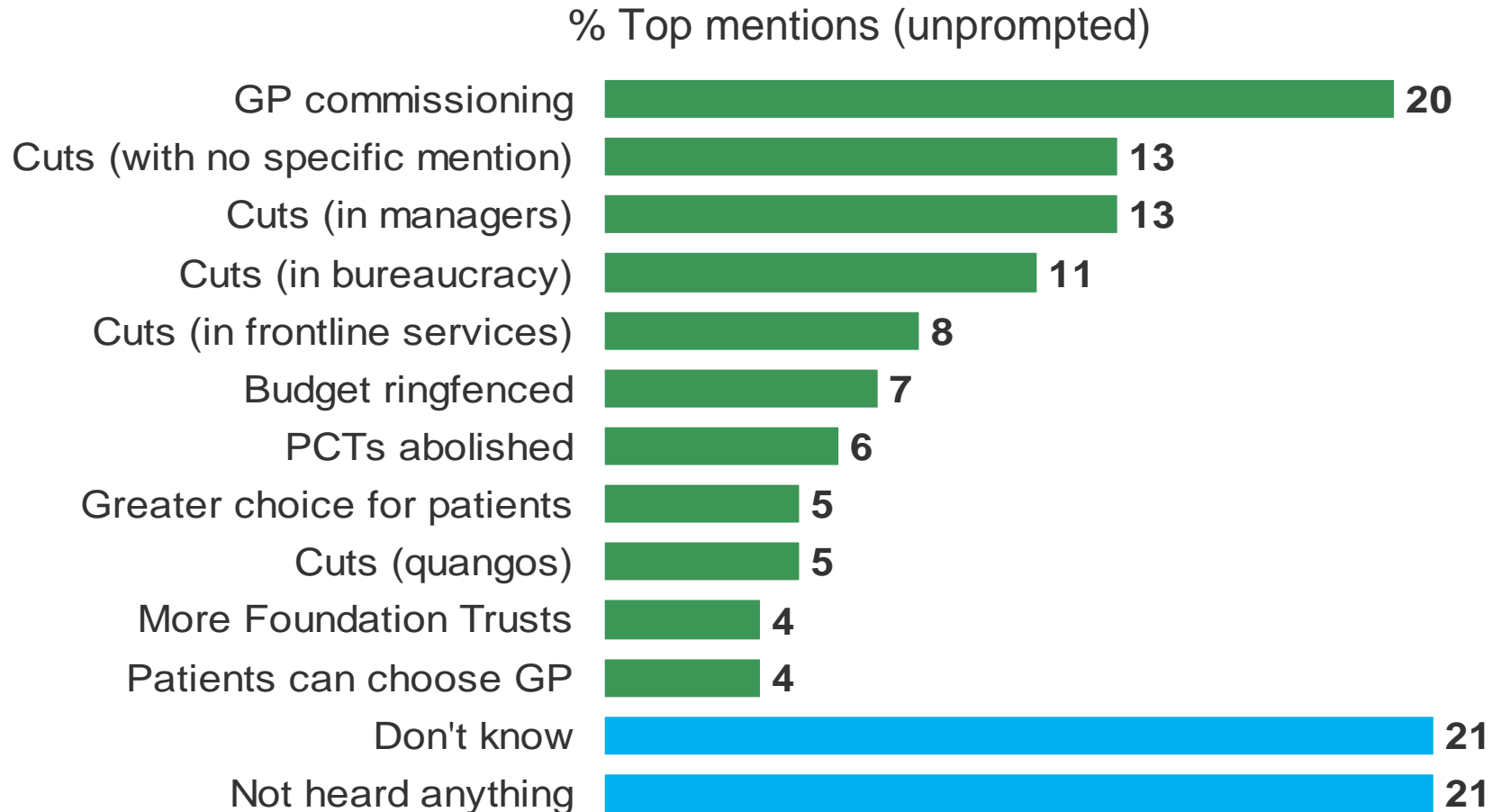

Base: 1,715 English adults interviewed face to face between 30<sup>th</sup> July and 5<sup>th</sup> August 2010 (Ipsos MORI Capibus)

# Concern over cuts probably driving pessimism

Thinking about the changes that will be made to the NHS... To what extent do you think these will make the NHS better or worse over the next few years, or will it stay the same?\*

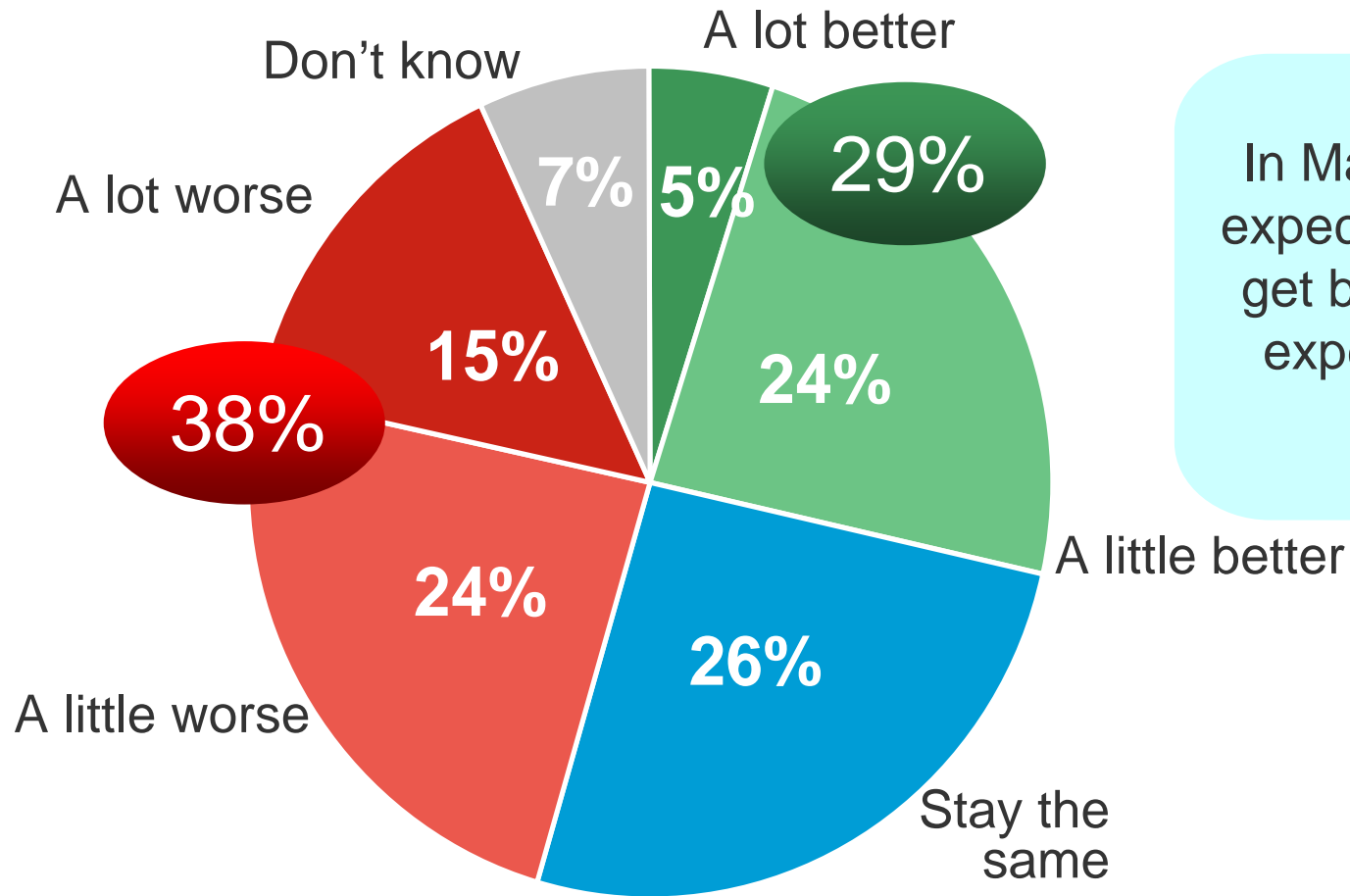

In March 2010 25% expected the NHS to get better and 33% expected it to get worse.\*\*

Base: 1,011 English adults who recall one or more changes. Interviewed face to face between 30th July and 5th August 2010 (Ipsos MORI Capibus) \*\*Source: Ipsos MORI/DH Perceptions of the NHS Tracker C.1,000

# Two in five believe that GP commissioning will be good for the NHS

The Government has announced that GPs will have more say in the way the NHS spends its money. To what extent do you think this particular policy will make the NHS better or worse over the next few years, or will it stay the same?

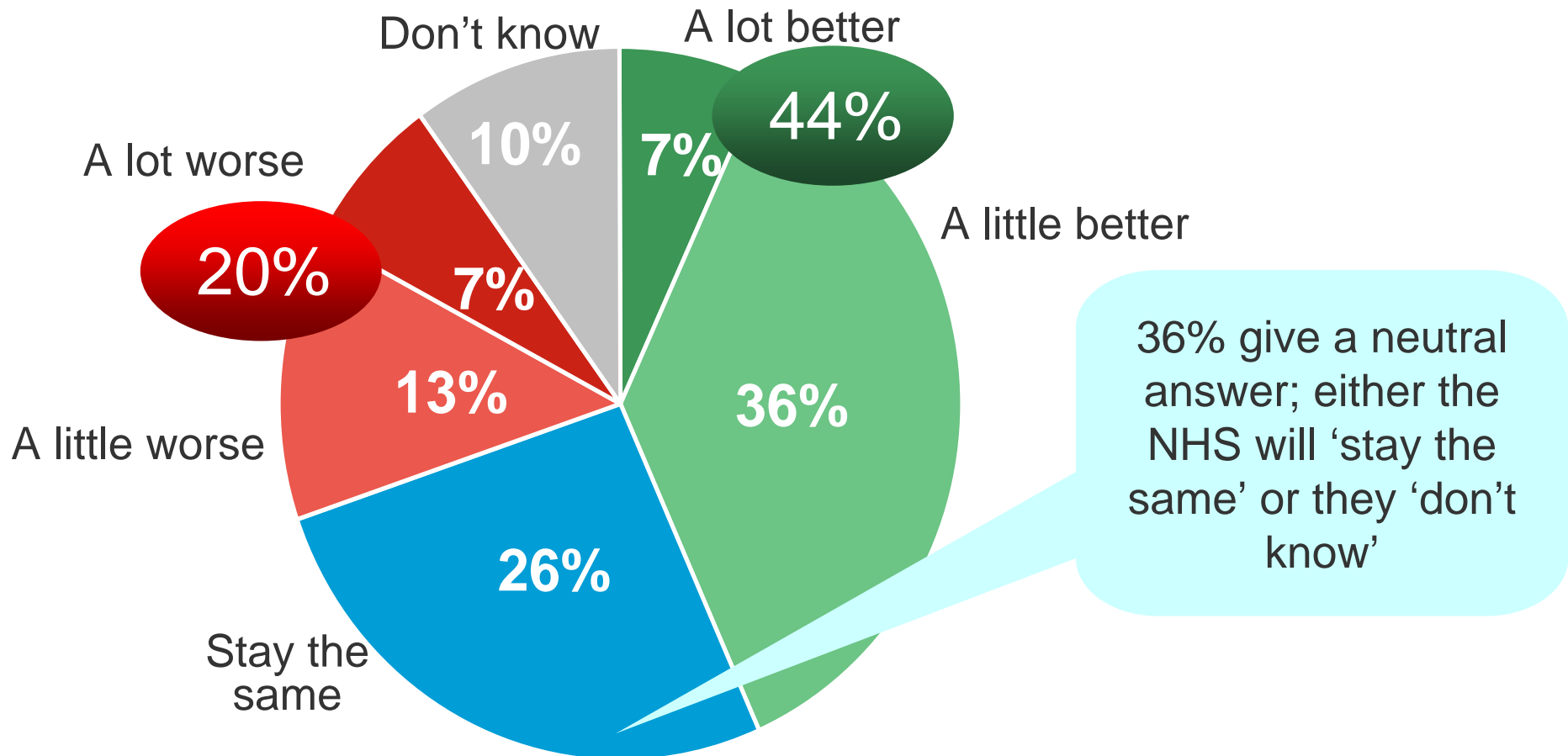

Base: 863 English adults interviewed face to face between 30th July and 5th August 2010 (Ipsos MORI Capibus)

# Think about who the public trusts

Q. For each, would you tell me whether you generally trust them to tell the truth or not?

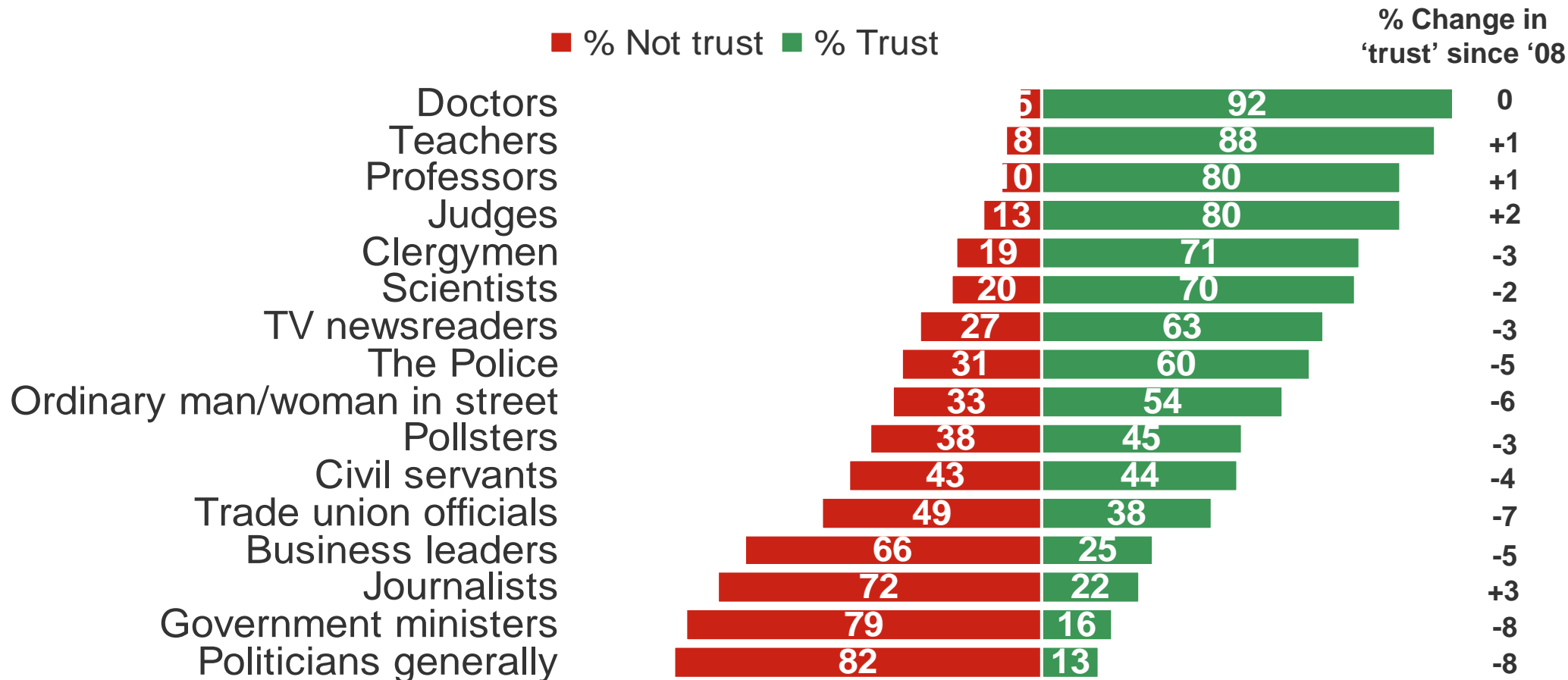

Base: 2,023 British adults aged 15+, 4-10 September 2009

Source: Ipsos MORI/RCP

Will relationship with  
GPs change?

Age of Transparency: does it mean explicit rationing?

Can you communicate rationing to the public?

# It *is* possible to engage the public constructively in this debate

- Despite kneejerk reactions on funding, there is an **underlying realism**
- As people become more engaged in the debate there's an **increasing recognition** of need to prioritise and ensure value for money
- Knee jerk **reactions to press stories change** when presented with fuller picture
- Think about difference between **public and patients**
- And they **want clinicians to be actively engaged** in this debate
- **But it is tough!**

# Attitudes are not set in stone

- The NHS should provide **all drugs and treatments no matter what they cost**
- The NHS should provide the **most effective drugs & treatments no matter what they cost**
- The NHS should provide the most effective drugs and treatments provided they represent good value for money
- Don't know

Beginning of day

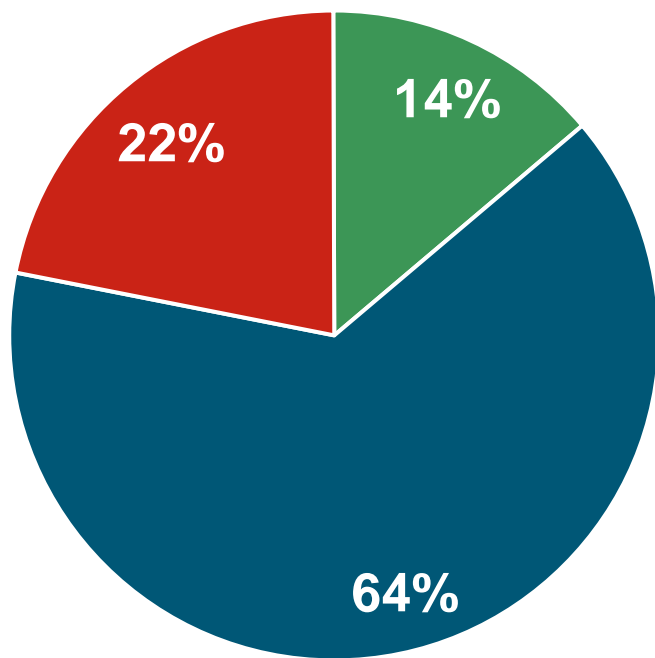

End of day

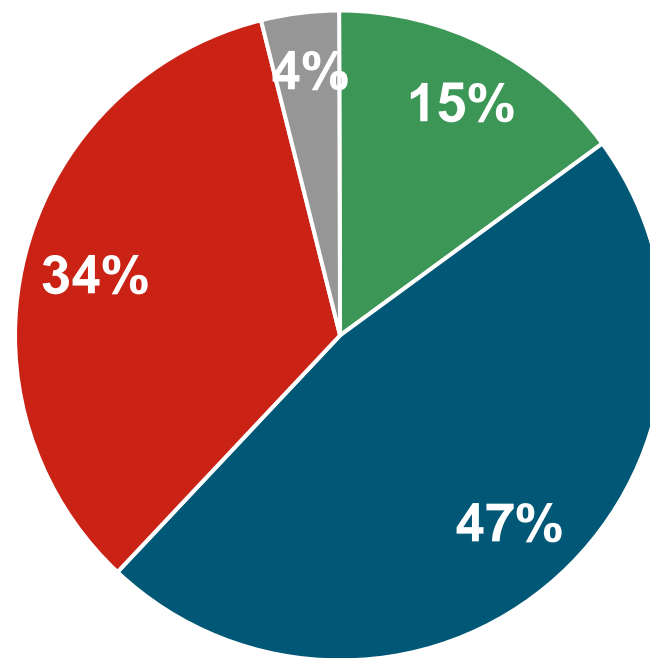

Base: British public, 18+ (90) Birmingham

So what is the answer? What do we want?

# The psychological contract

Q Please tell me whether on the whole you agree or disagree with each of the following statements?

**Britain's National Health Service is one of the best in the world**

**The NHS will be there for me when I need it**

**My local NHS helps improve the health and wellbeing of me and my family**

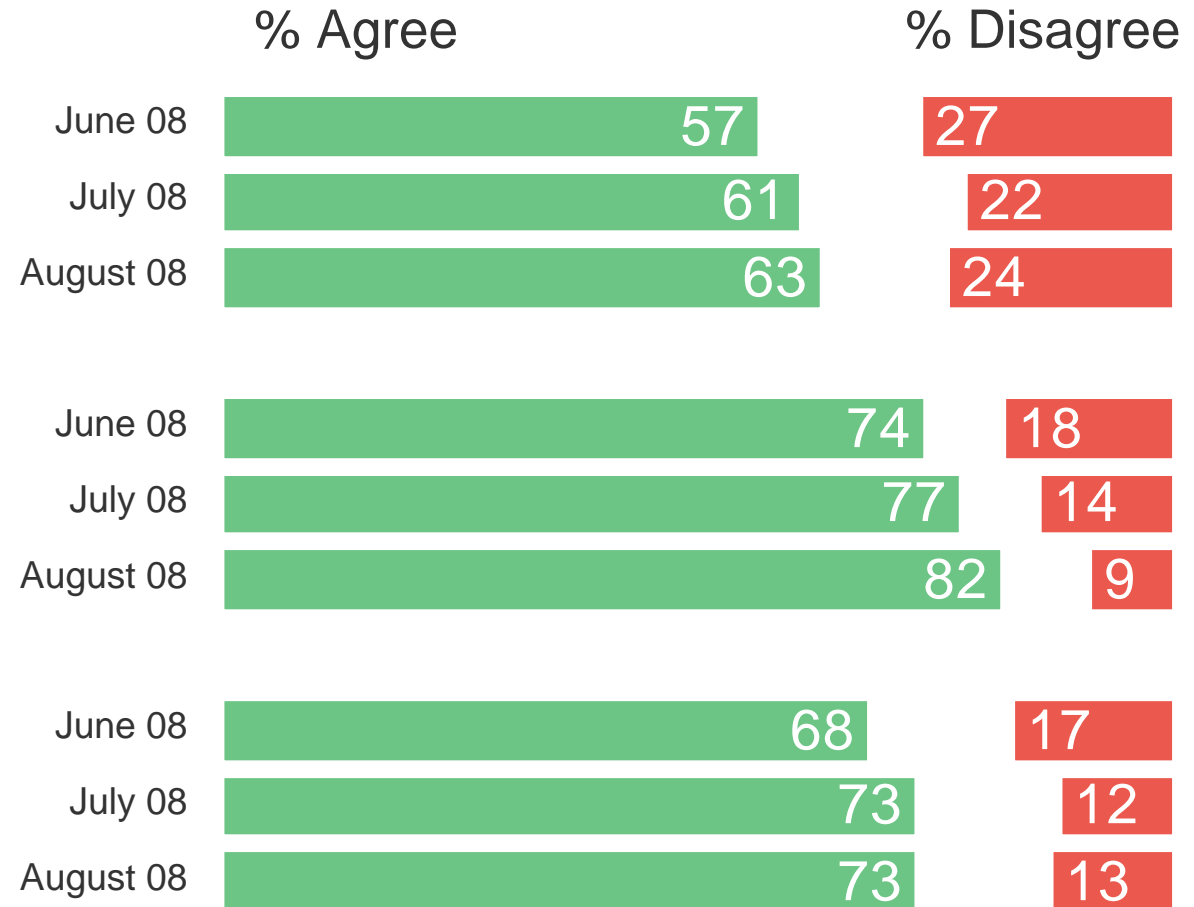

Base: English adults aged 16+ (c. 900 per wave) N.B arrows represent significant differences in agreement from June-Aug 08

*It's our health service....if you're hurt, injured or just generally unwell the best doctors in the country will come... and do whatever they need to do to repair whatever your problem is ... It's free at the point of delivery so anyone can turn up and be treated and not have to worry about paying for it at that point.*



Focus group participant, London, April 2010

# So how do you bring public with you?

- Communicate honestly
- Be clear what choice means
- Show choice drives up quality across the board
- Think about ways of communicating
- Be clear who you are communicating with
- Scope of involvement needs to be clear
- Challenge is converting positivity towards involvement to active participation
- Show it has made a difference
- Strong leadership

# So what do we want the NHS to be ?

- Fair
- Uniform
- Top quality
- Convenient
- National standards with local control
- To have unlimited resources

Thank  
you

[dan.wellings@ipsos.com](mailto:dan.wellings@ipsos.com)

**Ipsos MORI**